

7LR

65 - 70 kNm	7,8 - 9,4 m	3,4 - 3,5 m	3,8 m	2.070 - 2.200 kg	420°	20 kNm	190 bar	1x Minimum 80 l/min ~ 28 kW	2x Minimum 60 l/min ~ 45 kW	LS Minimum 150 l/min ~ 53 kW

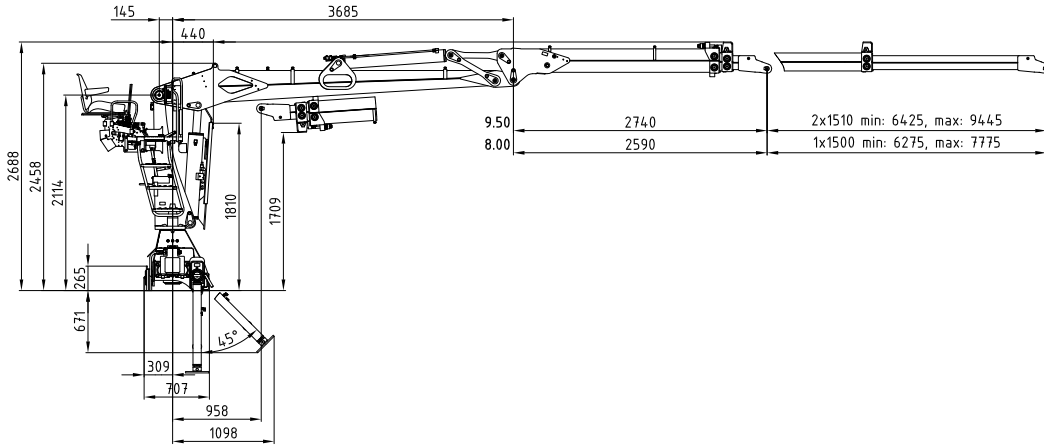

9.50 8.00

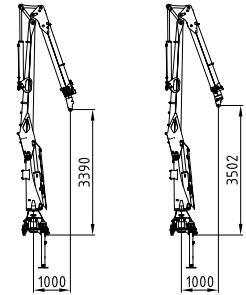

Kransockel schmal
Crane base small

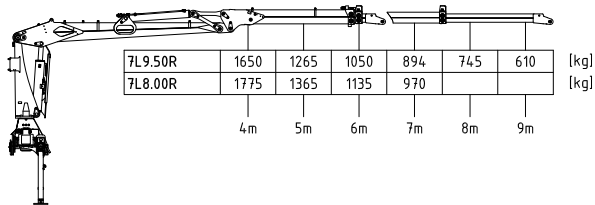
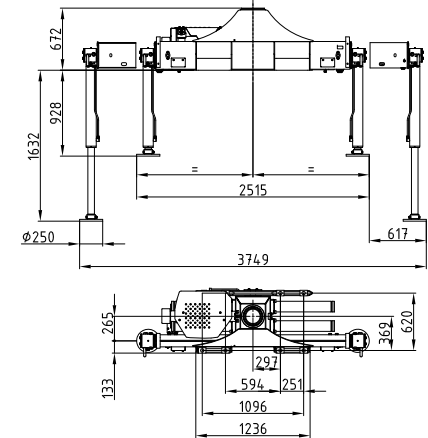

Rücksitz 01
Back seat 01

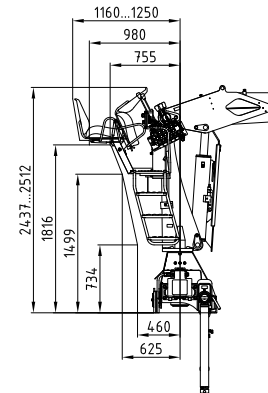

Rücksitz 04
Back seat 04

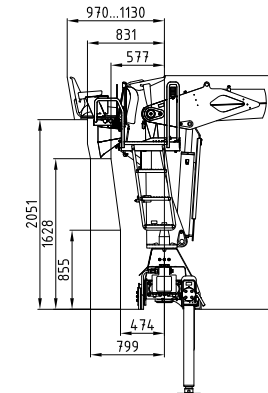

Seitensitz 04
Side seat 04

